

DKXM500 Case Erector

Technical Specifications & Configuration

1. Product Drawings

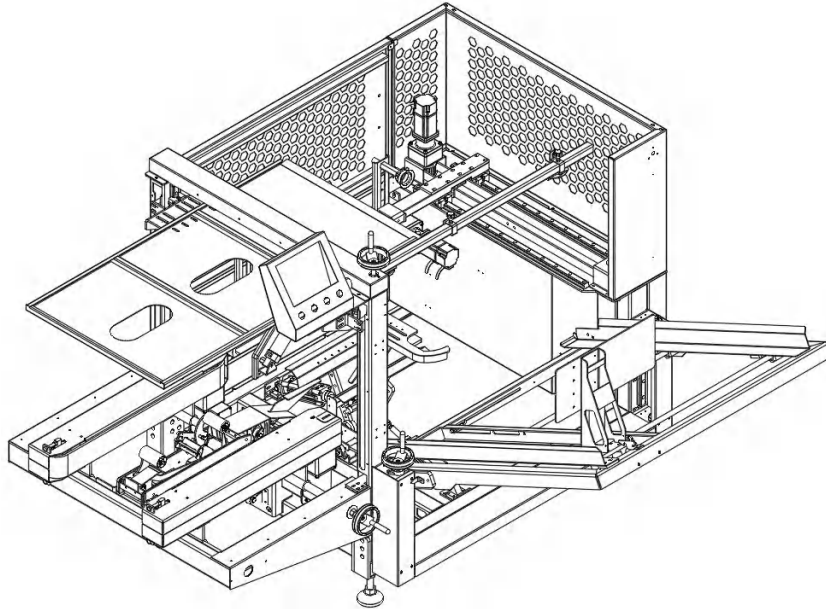

Appearance Drawing

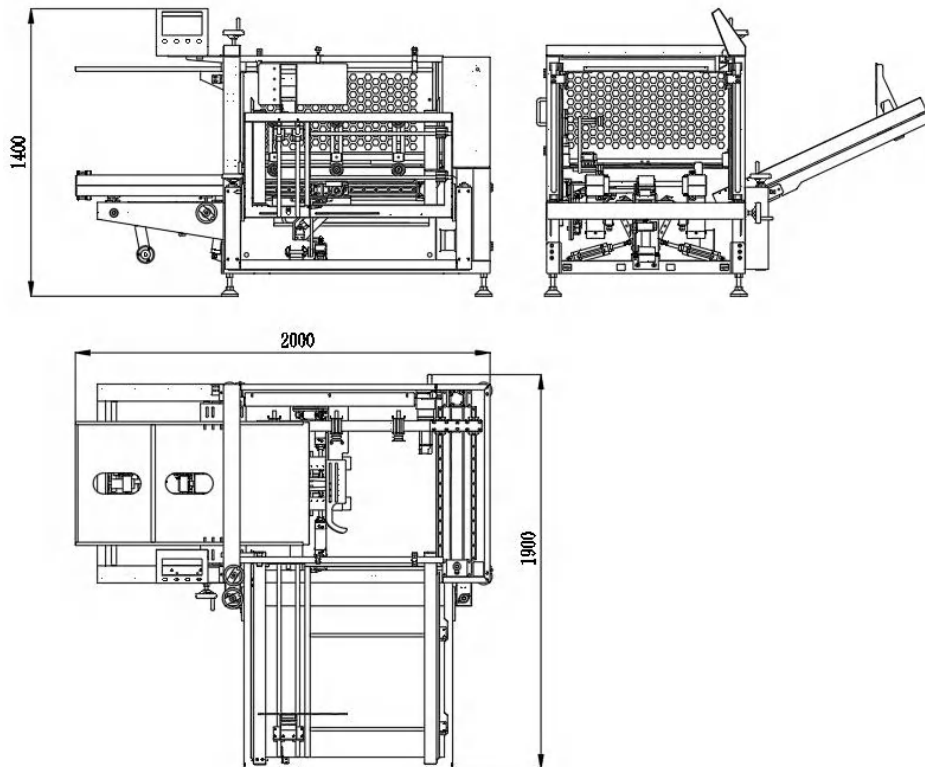

Dimension Drawing

2. Technical Specifications

DKXM500 Parameter Table		
Erecting Speed (cases/min)	≤14 (depending on carton size and quality)	
Carton Size Range (200≤H+W/2 < 580) (335≤L+W≤870)	Length L (mm)	280-500
	Width W (mm)	135-400
	Height H (mm)	150-400
Total Power (kW)	1	
Air Pressure Supply (MPa)	0.6~0.7	
Net Weight (kg)	350	
Machine Dimensions (L×W×H, mm)	2000×1900×1400	
Power Supply	220V 1PH 50Hz	
Tape Width (mm)	≤50	
Tape Diameter (mm)	≤250	
Color	Matte Silver	
Magazine Type	Inclined carton magazine	

3. Main Features



- **Compact and simple structure with small footprint; easy to operate and maintain; suitable for various industries.**
- **Continuous carton picking and conveying system with high speed; equipped with recipe function for quick changeover.**

- Carton picking and pushing are driven by dual servo motors, ensuring precise positioning without manual adjustment.
- Inclined, non-powered carton magazine allows continuous replenishment without stopping the machine.
- Seamless integration with upstream and downstream equipment.

4. Configuration List

Configuration List			
No.	Component	Brand	Remarks
1	Bearings	Renben	\
2	Linear Guides	Renben	Alternative brands available
3	Pneumatic Components	Airtac	Alternative brands available
4	Gear Motor	Xinbao	Alternative brands available
5	Suction Cups	Alberts	Alternative brands available
6	PLC	Inovance	\
7	Touch Screen	Inovance	\
8	Servo Motor	Inovance	\
9	Circuit Breaker	Chint	Alternative brands available
11	Push Button Switch	Senao	Alternative brands available
12	Sensor	SICK	\

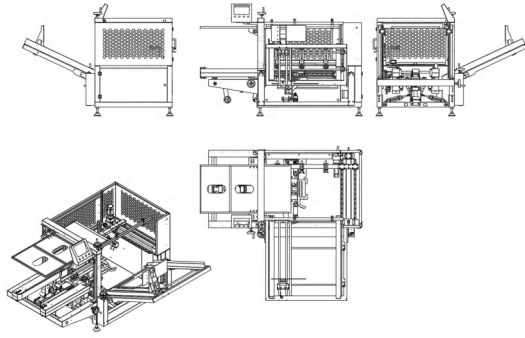
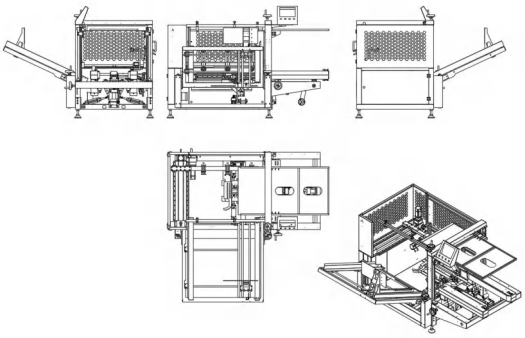
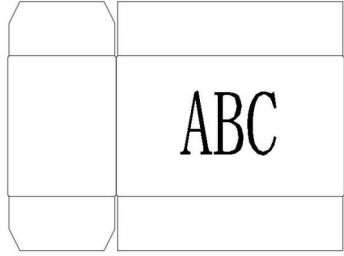
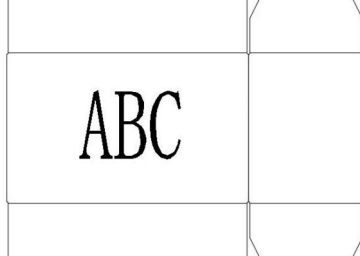
5. Carton Requirements for Case Erector

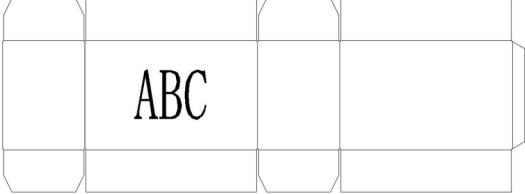
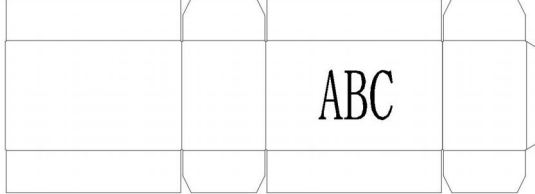
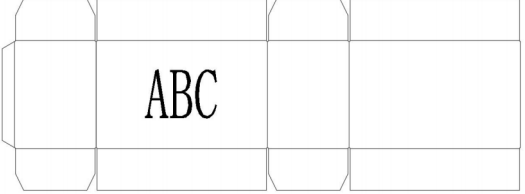
Case Erector Direction and Carton Orientation Matching Table	
Forward Case Erector (cartons fed from right, discharged to left)	Reverse Case Erector (cartons fed from left, discharged to right)
	
Forward Carton	Reverse Carton
 <p>Forward Carton (Folded State) Face this side, with text facing upward</p>	 <p>Reverse Carton (Folded State) Face this side, with text facing upward</p>
 <p>Forward Carton (Flattened State) Face this side, with text facing upward</p>	 <p>Reverse Carton (Flattened State) Face this side, with text facing upward</p>
 <p>Forward Carton (Flattened State) Face this side, with text facing upward</p>	 <p>Reverse Carton (Flattened State) Face this side, with text facing upward</p>

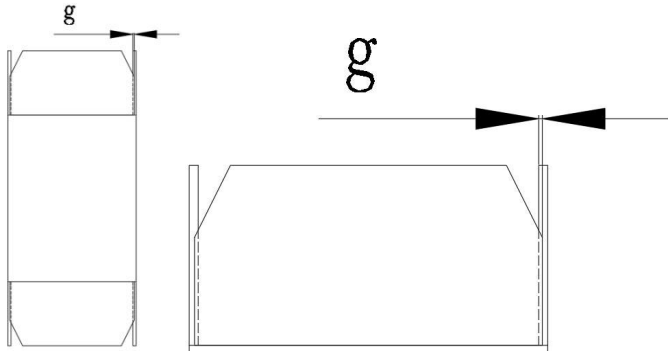
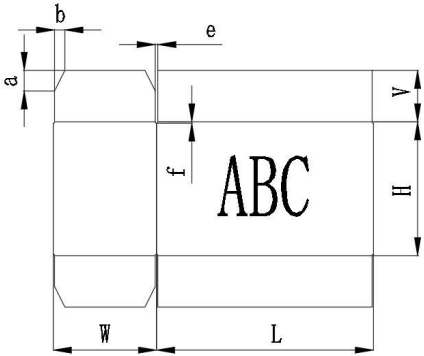
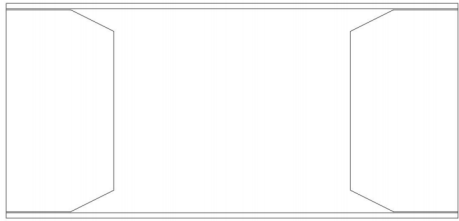
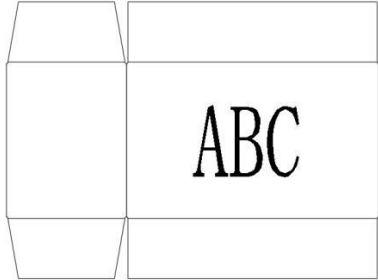
Corner Cut Dimensions a and b	
Reason for Corner Cutting	To ensure smoother and more stable folding of carton flaps, and to prevent the carton type, size, and board quality from affecting erecting speed and forming quality.
$a = W/2 \times (2/5)$, or $a = W/2 \times (1/2)$ in special cases $b = 4 \times \delta$, where δ is the cardboard thickness For cartons with similar dimensions, a unified and appropriate corner cut size can be selected.	
Criteria for Corner Cutting	<ol style="list-style-type: none"> ① The cardboard is hard and thick, with shallow creases ② The carton is wide and short (width/height ≥ 3) ③ Dimension "e" is too small, or dimensional deviations cause interference (as shown below) The larger the dimension "g", the greater the folding resistance <div style="text-align: center;">  </div> <ol style="list-style-type: none"> ④ E-flute cartons (micro-flute) may not require corner cutting ⑤ Small-sized cartons may not require corner cutting
Correct Corner Cutting	<div style="display: flex; align-items: center;"> <div style="margin-right: 20px;">  </div> <div>  </div> </div>
Incorrect Corner Cutting	

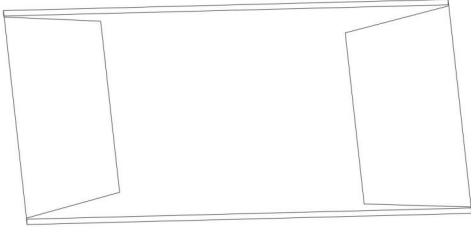
	 <p>Insufficient support at the base may cause carton skewing and misalignment.</p>
--	--

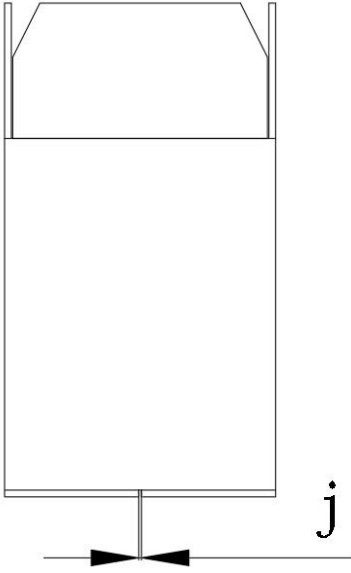
Dimension V and Overlap Dimension k	
Reason	Overlap of the side flaps affects erecting speed and carton forming quality
Adjust dimension V according to $0 \text{ mm} \leq j \leq 3 \text{ mm}$ Fold and flatten both side flaps of the carton. In the natural state (do not clamp both sides; refer to left-right direction as shown)	
Non-overlapping Condition	<p>In the natural state, there is a gap between the two side flaps after folding and flattening. After being clamped by the belts, j becomes 0.</p> <div style="text-align: center;">  <p>The diagram shows a side view of a carton with its top flaps folded down. A vertical line with arrows at both ends indicates the gap between the two side flaps, labeled with the letter 'j'.</p> </div>

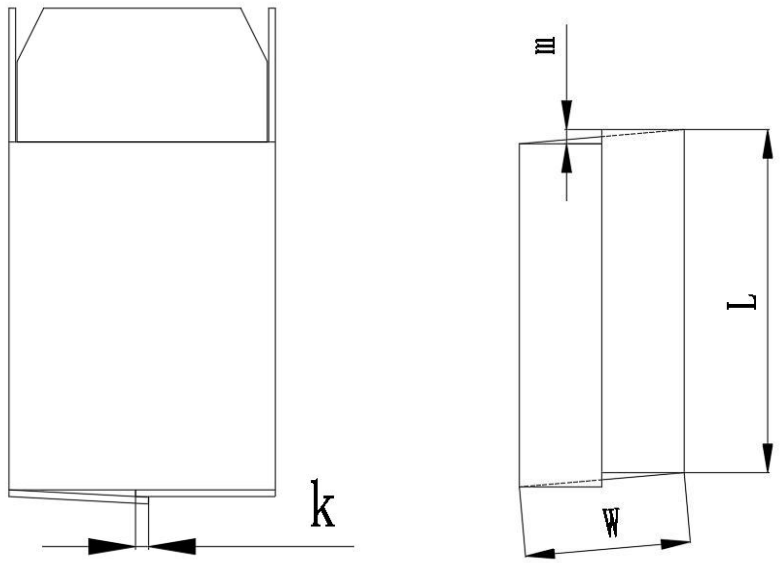
<p>Overlapping Condition</p>	 <p>In the natural state, the two side flaps overlap after folding and flattening. This may cause carton skewing, misalignment, and overlap issues.</p> <p>Adjust dimension V so that it meets $0 \text{ mm} \leq j \leq 3 \text{ mm}$.</p>
----------------------------------	--

Overlap Dimension P	
Reason	Misalignment of the carton joint (gluing position) may cause erecting failure and affect carton forming quality.
Control dimension P accordingly.	
Misalignment Condition	
	<p>Misalignment at the carton joint can cause flap interference, making the front and rear flaps difficult to fold. This may result in carton skewing and improper alignment.</p> <p>This issue is more common in stitched cartons, which are typically rigid and difficult to form manually.</p>